

Front view and mounting

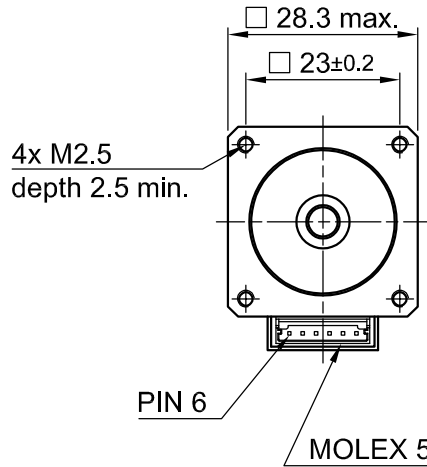

Side view

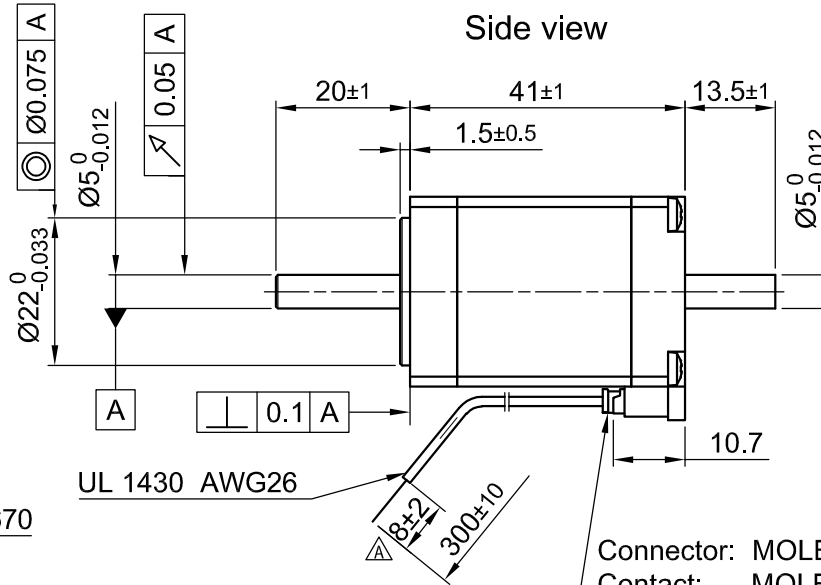

Rear view

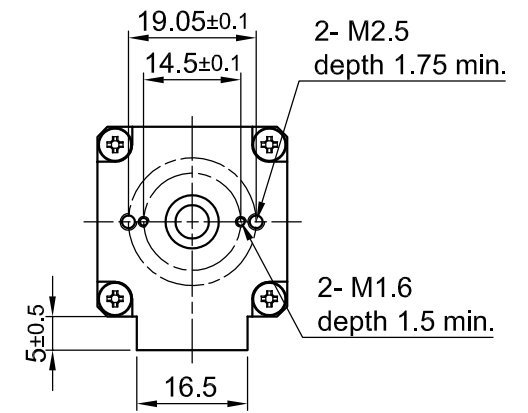

Connector: MOLEX 51065-0600  
Contact: MOLEX 50212-8000

SPECIFICATION	CONNECTION	BIPOLAR SERIES
VOLTAGE (VDC)		4.9
AMPS/PHASE		0.67
RESISTANCE/PHASE (Ohms)@20°C		7.3±10%
INDUCTANCE/PHASE (mH) @1KHz		6.52±20%
HOLDING TORQUE (Nm) [lb-in]		0.135 [1.19]
STEP ANGLE (°)		1.8
ACCURACY (NON-ACCUM)		±5%
ROTOR INERTIA (Kg-m <sup>2</sup> ) [lb-in <sup>2</sup> ]		1.2x10 <sup>-6</sup> [0.004]
WEIGHT (Kg) [lb]		0.14 [0.31]
TEMPERATURE RISE: MAX.80°C		
ATTN: MAKE SURE TEMPERATURE OF MOTOR CASE REMAINS BELOW 100°C		
AMBIENT TEMPERATURE -20°~ +50°C [-4°F ~ 122°F]		
INSULATION RESISTANCE 100 MOhm (UNDER NORMAL TEMPERATURE AND HUMIDITY)		
INSULATION CLASS B 130° [266°F]		
DIELECTRIC STRENGTH 500VAC FOR 1 MIN. (BETWEEN THE MOTOR COILS AND THE MOTOR CASE)		
AMBIENT HUMIDITY MAX. 85% (NO CONDENSATION)		

PERMISSIBLE RADIAL+AXIAL FORCE

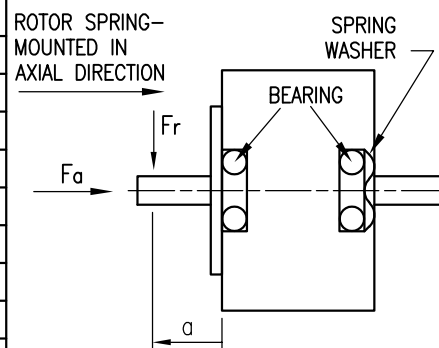

AXIAL-FORCE Fa (N)	Fr (N)	AXIAL	RADIAL
Fa=7	28 max.	0.08	0.02
DISTANCE a (mm)		AT LOAD MAX. (N)	
5		4	4

TYPE OF CONNECTION (EXTERN)	MOTOR			
	BIPOLAR	CONNECTOR PIN NO.	LEADS	WINDING
A —	1	BK	A	[Winding Diagram]
A\ —	3	GN	A\	
B —	4	RD	B	[Winding Diagram]
B\ —	6	BU	B\	

FULL STEP 2 PHASE-Ex., WHEN FACING MOUNTING END (X)

STEP	A	B	A\	B\	CCW	CW
1	+	+	-	-	↓	↑
2	-	+	+	-	↑	↓
3	-	-	+	+	↓	↑
4	+	-	-	+	↑	↓

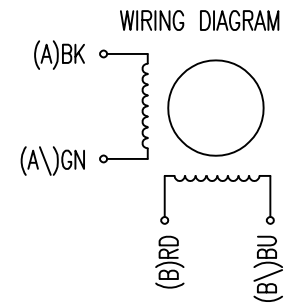

				 PLUG & DRIVE			APVD	G.S.	19.07.16	STEPPING MOTOR	
A	-	23.10.17	G.S.	Surface specification	General tolerances	Work piece edge	CHKD			DWG.NO	
REV	DESCRIPTION	DATE	DRN	DIN ISO 1302	DIN ISO 2768- ch	DIN ISO 13715	DRN	A.S.	14.07.16	SC2818M0604-B	
							SIGNATURE		DATE		